

Could KellGold* be the Holy Grail of Refractory Gold Processing?

*Adams, et al., 2015

Kell has been successfully tested for PGM concentrate treatment as a replacement for the conventional smelter and base metal/PGM refining route. Utilising a similar process for difficult gold ores could open up refractory gold processing opportunities.

Kell Platinum Process Flow Schematic

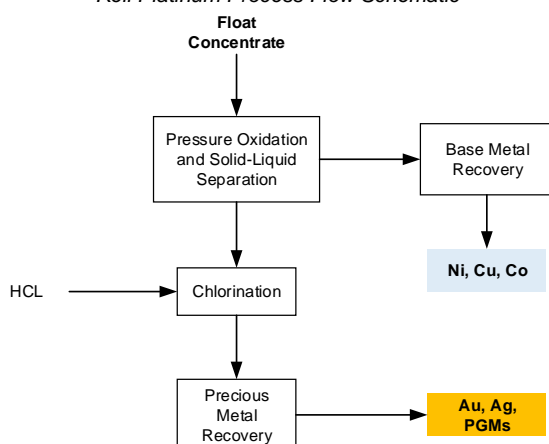

NEWSLETTER SPOTLIGHT

Advantages of Kell processing of refractory gold concentrates:-

- ◇ No constraints on float concentrate grades or deleterious elements.
- ◇ Cyanide-free process.
- ◇ Comply with government local beneficiation requirements.
- ◇ 99% gold can be produced on site.

Kell is a chemical process developed and successfully tested to recovery platinum group metals (“PGM”) and base metals from sulphide float concentrates. It is gaining momentum and could eventually upheave the platinum smelters monopoly. Using similar processing units as the Kell platinum process, KellGold can recover gold, silver, base metals and rare metals from a range of refractory sulphide concentrates that respond poorly to conventional cyanide recovery methods.

Kell is gaining momentum and could eventually upheave the platinum smelting industry. Could the same be said for its application for processing of refractory gold ores?

Exploration of large free-milling gold deposits has declined to a point that mining companies have started looking at low-grade deposits or smaller, more complex orebodies often found in remote and hard to reach locations. These orebodies often have refractory, double-refractory, pre-robbing or reagent consumer characteristics.

Referring to the figure to the right, current available treatment processes for these ores typically include fine grinding, roasting, pressure oxidation (“POX”) and atmospheric acid oxidation or biological oxidation, followed by cyanide leaching. These processes are limited by flotation concentrate grade as well as deleterious elements. Furthermore, the downstream cyanidation leaching processes are limited by deleterious elements produced or liberated during the pre-treatment step.

Refractory Gold Processing Flow Options

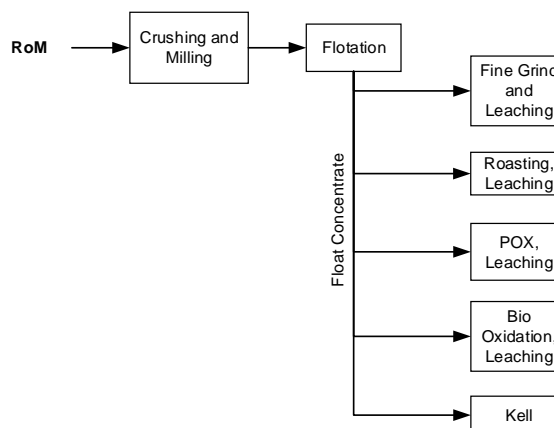

KellGold utilises commercially proven unit operations and learnings from processing of PGM concentrates through the Kell Process. The following benefits could be realised for KellGold (Adams, *et al.*, 2015):-

- No constraints on flotation concentrate grades or impurities which could increase float mass pull and recoveries;
- Cyanide free gold recovery which negates the need to destroy the cyanide in tailings streams – some countries ban the use of cyanide altogether;
- Reduced water usage, carbon dioxide emissions and electricity usage;
- Improved profitability due to higher metals recoveries and lower operating costs in comparison with toll smelting (this would have more of a benefit for gold producers in remote countries that do not have nearby gold refineries);
- Ability to produce refined metals at the mine site which would comply with certain governments beneficiation requirements.

Toll refining in South Africa (at Rand Refinery) costs less than 1% of the gold produced. As a result, smelting costs savings would be more prevalent for gold producers in countries that do not have a gold refinery.

Reagent consumer metals such as nickel, copper and cobalt are first selectively removed through a pressure oxidation step. A chloride leach similar to the Minataur Process (Scott and Matchett, 2005) then follows. Gold is selectively extracted from the gold-chloride species by means of solvent extraction and then scrubbing stages to remove impurities. Preliminary assessments for KellGold process (Adams *et al.*, 2015) achieved gold (Au) recoveries of between 87% and 100% for various refractory gold-bearing ores. Conventional cyanide leaching of the same ores exhibited Au recoveries of 3% to 82%.

Beyond that, no further testwork or feasibility work has been published in the public domain. This begs the question: is KellGold the answer to refractory gold processing? Referring to the figure below, various processing options are compared for a southern Africa refractory gold orebody studied by Minxcon.

Capital, Operating Costs and Recoveries for Various Refractory Gold Processing Methods

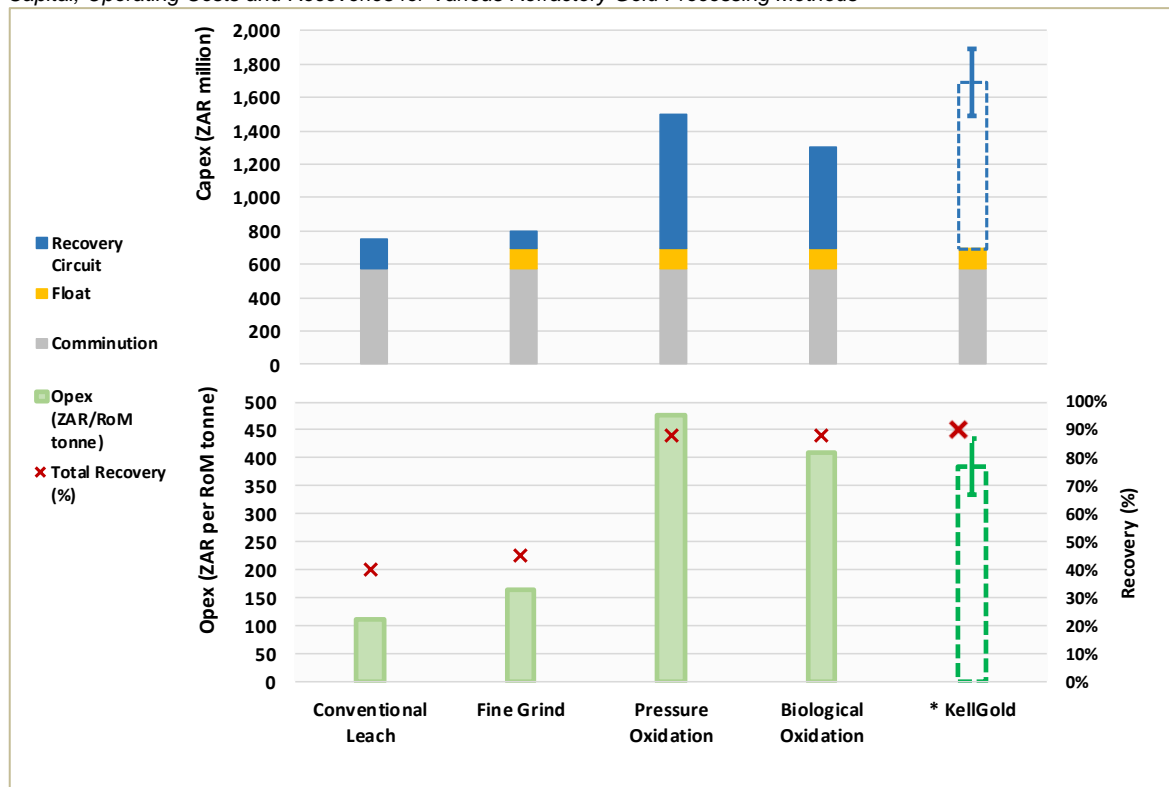

Note: * Average KellGold recovery achieved in the testwork programme reported in Adams *et al.* (2015).

The graph highlights the capital, operating cost and recovery differences between processing options considered in the project. Conventional leaching and fine grinding options were expected to achieve recoveries of 40% and 45% respectively compared with the 88%+ recoveries expected from POX and biological oxidation. Operating and capital costs for the pressure oxidation are higher than biological oxidation. Furthermore, there is a recovery benefit with pressure oxidation. Owing to the lower capital costs, availability of specialised operational expertise and its successful application in southern Africa, biological oxidation was selected as the preferred processing route for the project.

Although not considered for this refractory gold project, KellGold could offer further value to the project as it is expected to achieve a higher recovery than POX and biological oxidation with less stringent deleterious and gold grade requirements on the float concentrate. However, it is anticipated that the KellGold Process could be more capital intensive but have a similar operating cost as a biological oxidation process. With a long life of mine, a slightly reduced operating cost and improved recovery would typically outweigh the high capital.

KellGold has the potential to upheave refractory gold processing and open up further mining opportunities for orebodies that have not been economically extractable with current technologies. However, thorough amenability testwork will still be required as part of the trade-off phases of a pre-feasibility study to compare all processing methods and to make an informed decision.

References

- Adams, M.D., Liddell, K.S., Smith, L.A., 2015. The KellGold hydrometallurgical process for cyanide-free extraction of gold from refractory concentrates and feedstocks – a preliminary assessment. *The Southern African Institute of Mining and Metallurgy*, World Gold Conference 2015.
- Scott, S.A., Matchett, K., 2004. Minataur™: the Mintek alternative technology to gold refining. *The Journal of The South African Institute of Mining and Metallurgy*, 339-344.

**For more information please contact
Dario Clemente at dario@minxcon.co.za**



A project management company specialising in the management and optimisation of exploration projects within the mining industry.



An advisory company that offers a wide range of mining consulting services, including Resource and Reserve Statements, Competent Persons' Reports and Technical Reports..



Engineering, Metallurgy, Capital Cost Estimation, EPCM and Project Management services in the minerals industry, including feasibility study work, plant design and construction.

TARGET | EXPLORE | COMPLY

RESOURCE | RESERVE |
VALUE

DESIGN | BUILD | OPTIMISE

CONTACT US

Tel: +2711 958 2899

Email: reception@minxcon.co.za

Web: www.minxcon.co.za

Address: Suite 5, Coldstream Office Park, Cnr Coldstream Str & Zandvliet Roads, Little Falls, Roodepoort, SOUTH AFRICA

Copyright © 2018, All rights reserved